



# LOW PROFILE SERIES

MAIDA STYLE NUMBER R69ZOV391RA215

MAIDA ITEM NUMBER 01-1316

**VARISTOR SPEC SHEET**

### Electrical Specifications

Continuous AC Voltage	390 VAC
Continuous DC Voltage	505 VDC
Maximum DC Leakage @ 505 VDC	200 $\mu$ A
Low Varistor Voltage Limit	552 VDC
High Varistor Voltage Limit	674 VDC
Nominal Varistor Voltage	612 VDC
Current for Varistor Voltage	1 mA
Maximum Clamp Voltage	1025 V
Maximum Clamp Voltage Test Current	50 A
Peak Current Rating (1 Pulse)	6000 A
Peak Current Rating (2 Pulse)	4500 A
Energy Rating (8X20us)	215 J
Energy Rating (10X1000us)	215 J
Typical Capacitance	260 pF
Impulse Response Time	< 50 ns
Minimum Hipot of Coating	2500 VDC
Minimum I.R. of Coating	1000 M $\Omega$
Current/Energy Derating Above 85°C	-2.5 %/°C

### Thermal Specifications

Minimum Operating Temperature	-40 °C
Maximum Operating Temperature	85 °C
Varistor Voltage Temperature Coeff	-0.05 %/°C
Minimum Storage Temperature	-50 °C
Maximum Storage Temperature	125 °C
Recommended Solder Temperature	260 °C
Recommended Reflow Temperature	260 °C

### Notes

### Physical Specifications

Lead Style	082J1
X Nominal	0.3 in.
X Tolerance	0.04 in.
Y Nominal	0.17 in.
Y Tolerance	0.03 in.
Z Nominal	0.344 in.
Z Tolerance	0.04 in.
Lead Length Nominal	1.00 in.
Lead Length Tolerance	min. in.
d Nominal	0.032 in.
Wire Gauge	20 AWG
Minimum Marking	R69-391UL
Nominal Disk Size	12 mm
D Maximum	0.566 in.
T Maximum	0.325 in.
H Maximum	0.691 in.
Coating Type	EPOXY

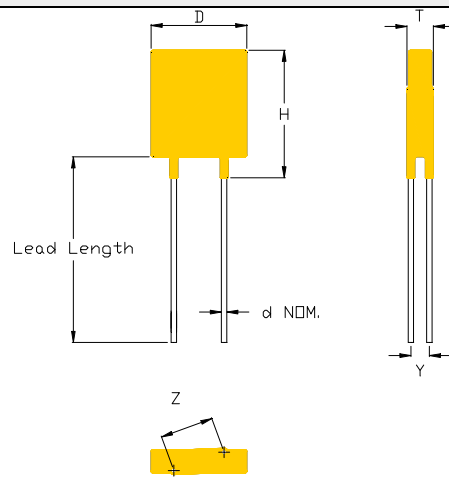

\* Contact Maida for a more detailed configuration drawing.

### Safety Agency Recognitions

UL 1449 File Number	E321173
- Tested to Type:	2
CSA File Number	LR33468
VDE File Number	
SEV File Number	



MAIDA DEVELOPMENT COMPANY

P.O. Box 3529

Hampton, Virginia 23663

www.maida.com

Ph: (757) 723-0785 Fax (757) 722-1194